

OVERVIEW

NevadaNano's MPS R-290 Sensor builds upon the fifth-generation of this breakthrough sensor technology, delivering industry-leading performance with a low cost of ownership. It quickly detects and quantifies R-290 with unprecedented accuracy, comes already factory calibrated for its entire 15+ year life—no field calibrations are required—and has built-in environmental compensation and automatic self-testing for fail-safe operation. The sensor is robust and extremely poison resistant. Readings are output on a digital bus or a configurable analog output.

The MPS R-290 Sensor is available in both the intrinsically safe certified S4 form factor as well as the Mini form factor.

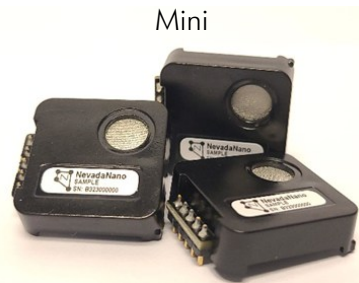

Series 4 ("S4")



GAS DETECTION

Range	Accuracy (5-25 %LEL)	Accuracy (>25 %LEL)
5-100 %LEL	±2.5 %LEL	±10 %

The volume percentage (%VOL) corresponding to 100 %LEL for R-290 (propane), in accordance with ISO 817 and 60335-2-40 (UL ed. 4, IEC ed. 7) at 25 °C and 1,013.2 mbar, is 2.1 %VOL.

PERFORMANCE

Resolution	0.1 %LEL
Response time (T90)	< 20 seconds
Calibration	Factory calibrated
Long-Term Stability	> 7 years demonstrated

ENVIRONMENTAL OPERATING RANGE

Temperature	-40 to 75 °C
Humidity	0 to 100 %RH
Pressure	80 to 120 kPa

SELF-DIAGNOSTICS

The MPS R-290 Sensor automatically performs a comprehensive sequence of self-checks at power-up, and every 2 seconds during operation to ensure fail-safe operation. The MPS alerts the user of any sensor failure or status alert. For additional information on how to interpret and handle detected faults, refer to the MPS R-290 Sensor User Manual at www.nevadanano.com/downloads

KEY FEATURES

- Accurate detection of R-290 (propane)
- Built-in environmental compensation
- Can detect gas presence at start-up
- Built-in self-test for fail-safe operation
- Supports 15+ year lifetimes
- No calibration required
- Extremely poison resistant
- Can be powered at 3V
- Low average power: 27.3 mW typical at 3V
- Custom analog out configurations
- Intrinsically safe (IS) certified (S4 only)
- Compliant to 60335-2-40 (UL ed.4, IEC ed.7)
- Compliant to IEC 60079-29-1 Edition 2.1 Annex A

OPERATING PRINCIPLE

The MPS transducer is a patented micro-machined membrane with an embedded Joule heater and resistance thermometer. The transducer is mounted on a PCB and packaged inside a rugged enclosure open to ambient air. Presence of R-290 causes changes in the thermodynamic properties of the air/gas mixture that are measured by the transducer. Sensor data are processed by patented algorithms to report an accurate concentration.

MECHANICAL AND ELECTRICAL INTEGRATION—MINI

The MPS Mini family of gas sensors is designed to be permanently mounted to a printed circuit board. In addition to the electrical interconnects, the Mini package has two features that can engage with two, unplated 1.10 mm to 1.50 mm diameter holes on the PCB for more precise and secure position of the sensor relative to the PCB.

MECHANICAL

Mass 4.3 ± 0.5 grams
 Body material PEI

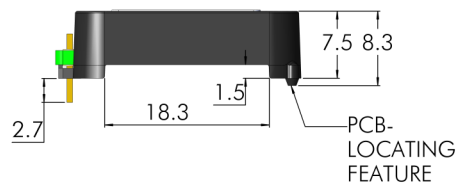
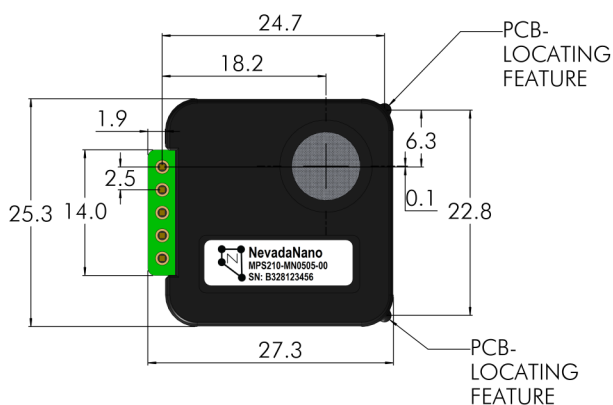

Dimensions in mm

ELECTRICAL

Operating voltage 3.0 - 5.0 ±5% VDC

Current consumption (typical)	Range	Start-up (~30 sec)	Average
	6-22 mA	21.1 mA, 3.3V supply 22.0 mA, 5.0V supply	9.1 mA, 3.3V supply 9.3 mA, 5.0V supply

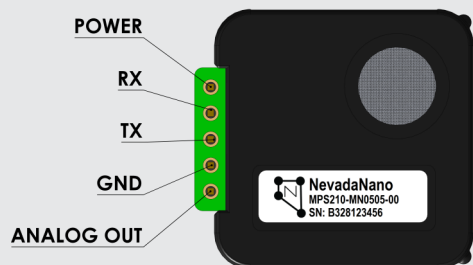

Communication: UART
 Logic signaling standard: 3.0 V
 Baud rate: 38,400. 8 data, 1 stop bits. No parity.
 RX Data Input : Do not exceed 3.6 V
 Input High Voltage (V_{IH}) = 2.0 V minimum
 Input Low Voltage (V_{IL}) = 0.85 V maximum
 TX Data Output : Source / Sink 4 mA maximum
 Output High Voltage (V_{OH}) = 2.45 V minimum
 Output Low Voltage (V_{OL}) = 0.45 V maximum
 Programmable Analog out (optional)

Analog voltage output (“Analog Out”)

Industry standard 0.4 to 2.0 Volt linearized, compensated for temperature, humidity and pressure. Different configurations available, including fault voltage, startup behavior, and “zero” voltage levels, all ranging from 0.04 to 2.4 Volts. These configurations also feature customized sensitivity slopes, which can include rising or falling Volts per %LEL. Contact NevadaNano for details.

MECHANICAL AND ELECTRICAL INTEGRATION—S4

The MPS R-290 Gas Sensor in IS form factor is a standard “4 series” size. The sensor interface pins are compatible with industry standard receptacles or socket assemblies.

MECHANICAL

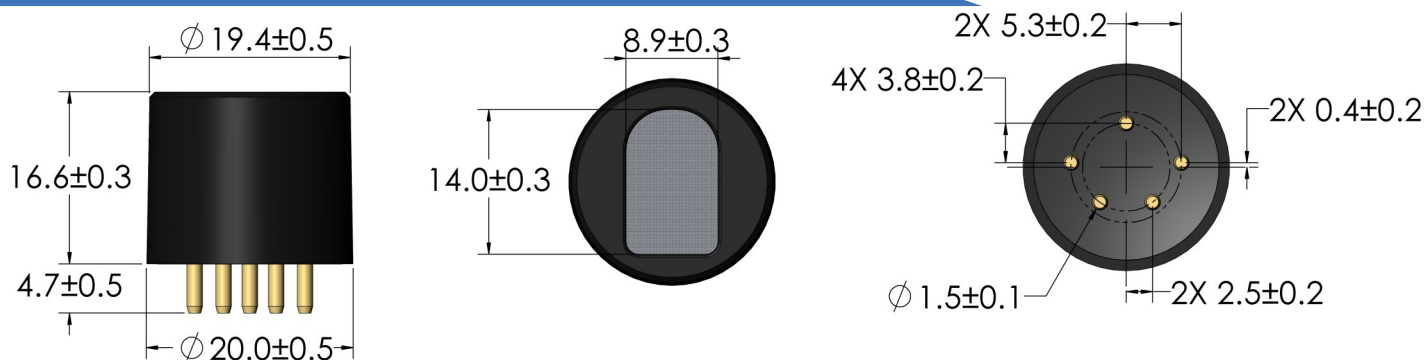

Dimensions in mm

Dimensions	16.6 mm (H) x 20.0 mm (D)
Mass	8.0 ± 0.5 grams
Body material	Ultem PEI

ELECTRICAL

Operating voltage	3.0 - 5.0 ±5% VDC		
Current consumption (typical)	Range	Start-up (~30 sec)	Average
	6-22 mA	21.1 mA, 3.3V supply 22.0 mA, 5.0V supply	9.1 mA, 3.3V supply 9.3 mA, 5.0V supply

5-pin
Digital Input/Output

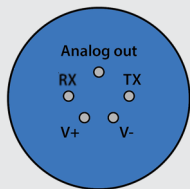

Bottom View

Communication: UART
 Logic signaling standard: 3.0 V
 Baud rate: 38,400. 8 data, 1 stop bits. No parity.
 RX Data Input : Do not exceed 3.6 V
 Input High Voltage (V_{IH}) = 2.0 V minimum
 Input Low Voltage (V_{IL}) = 0.85 V maximum
 TX Data Output : Source / Sink 4 mA maximum
 Output High Voltage (V_{OH}) = 2.45 V minimum
 Output Low Voltage (V_{OL}) = 0.45 V maximum
 Programmable Analog out (optional)



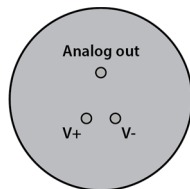

3-pin Pellistor Replacement
Programmable Output



Bottom View

Industry standard 0.4 to 2.0 Volt linearized, compensated for temperature, humidity and pressure. Different configurations available, including fault voltage, startup behavior, and “zero” voltage levels, all ranging from 0.04 to 2.4 Volts. These configurations also feature customized sensitivity slopes, which can include rising or falling Volts per %LEL. Contact NevadaNano for details.

CERTIFICATION—S4 (INTRINSICALLY SAFE) FORM FACTOR ONLY

				
Certification Body		ATEX NB 2809	UKEX AB 1725	
Certificate	IECEx FMG 19.0028U	FM19ATEX0184U FM21UKEX0159U	FM19US0145U	FM19CA0077U
Protection Categories	Ex ia IIC Ga Ex ia IIIC Da Ta = -40 °C to 75 °C	 II 1 G Ex ia IIC Ga  II 1 D Ex ia IIIC Da Ta = -40 °C to 75 °C	Class I, Division 1, Group A,B,C,D Class II and III, Division 1, Group E,F,G Class I, Zone 0 AEx ia IIC Ga Zone 20 AEx ia IIIC Da Ta = -40 °C to 75 °C	Class I, Division 1, Group A,B,C,D Class II and III, Division 1, Group E,F,G Class I, Zone 0 Ex ia IIC Ga Zone 20 Ex ia IIIC Da Ta = -40 °C to 75 °C

Certificates of Compliance	Specification	Test Lab/Certification Body	Certificate/Report Number
IECEx Quality Assessment Report	IEC 80079-34:2018	FM Approvals LLC	GB/FME/QAR19.0020/00
ATEX Quality Assurance Notification	2014/34/EU	FM Approvals LLC	FM19ATEXQ0200
UK Quality Assurance Notification	UKSI 2016:1107 (as amended)	FM Approvals LLC	FM21UKQAN0168

For additional information on certifications, refer to the MPS Hazardous Locations User Guide here: www.nevadanano.com/downloads

Certificates of compliance are available at www.nevadanano.com/downloads or by contacting NevadaNano.

CERTIFICATION—S4 AND MINI

Certificates of Compliance	Specification	Test Lab/Certification Body	Certificate/Report Number
Certificate of Registration of Quality Management System	ISO 9001:2015	National Standards Authority of Ireland (NSAI)	19.8213
RoHS (2 & 3) Compliant	2011/65/EU & 2015/863; includes China RoHS—SJ/T 11363 & 11364	Claigan Environmental & Supplier Declarations	CETR-NNT002.3
REACH Compliant	EC 1907/2006 (33 & 67)	Claigan Environmental & Supplier Declarations	CETR-NNT002.3

Certificates of compliance are available at www.nevedanano.com/downloads or by contacting NevadaNano.

ADDITIONAL TEST STANDARDS

Test	Specification	Summary of Test Conditions
Low Temperature Operating*	IEC 60068-2-1:2007	500 Hours @ -50°C
High Temperature Operating	IEC 60068-2-2:2007	1000 Hours @ 85°C
Mean Time to Failure (MTTF)	IEC 60068-2-2:2007	116 years at 60 % confidence or 35 years at 99 % confidence
Mechanical Vibration*	IEC 60068-2-6:2008	31Hz – 150 Hz (2G acceleration), 1 hour per axis, 3 axes
Mechanical Shock*	IEC 60068-2-27:2008	50G peak/11ms half sine pulse, 3 axes (positive and negative pulses)
Drop—Free Fall*	IEC 60068-2-31:2008	Procedure I: 1 meter drop onto concrete
Damp heat - steady state	IEC 60068-2-78:2012	500 hours @ 40°C/93% RH <i>[in test]</i>
Temperature cycling	JESD22-A104E	Test Condition N, -40°C to 85°C for 200 cycles
Sand/Dust Ingress Protection*	MIL-STD-810G	Method 510.5 Sand: 150-850 μ m SiO ₂ particle size, 23 m/s nom. velocity, 1.5 hrs @ 70°C per axis, 3 axes. Dust: Red China Clay, 1.5 m/s nom. velocity, 6 hrs @ 20°C, 6 hrs @ 70°C
Poisoning*	NevadaNano	1,200 ppm-hours H ₂ S (50 ppm for 24 hours) 10,400 ppm-hours siloxanes (Decamethylcyclopentasiloxane) (100 ppm for 4 hours, then 1,000 ppm for 10 hours) 0.25 ppm-hours NO ₂ (3 ppm for 5 minutes) 0.83 ppm-hours HCN (10 ppm for 5 minutes) 0.75 ppm-hours SO ₂ (9 ppm for 5 minutes) 0.17 ppm-hours Cl ₂ (2 ppm for 5 minutes) 4.17 ppm-hours NH ₃ (50 ppm for 5 minutes)
Electrostatic Discharge Immunity	JEDEC JS001-2017	Human Body Model, passed at 2 kV
EMC: Radio Frequency Electromagnetic Field Immunity	EN 61326-1:2020	Test Method EN 61000-4-3:2013 80 MHz to 6 GHz at 10 V/m, horizontal & vertical polarities. Class A.
EMC: Power Frequency Magnetic Field Immunity	EN 61326-1:2020	Test Method EN 61000-4-8:2010 30 A/m, 3 axes, 50 Hz and 60 Hz
EMC: Radio Frequency Disturbance Characteristics	EN 61326-1:2020	Test Method EN 55011:2010 30 MHz to 1 GHz. Class A.

The table above provides a summary of standardized tests and test conditions to which the MPS Flammable Gas Sensor 5.0 has been subjected and passed by demonstrating performance within the MPS Flammable Gas Sensor 5.0 specification both before and after each test. The MPS R-290 Sensor in both S4 and Mini form factors is qualified by assessed similarity.

**The MPS Flammable Gas Sensor 4.0 hardware passed this test, and the MPS Flammable Gas Sensor 5.0 and MPS R-290 are qualified by similarity.*

PART NUMBER ORDERING GUIDE

Please refer to the following tables below when ordering the MPS R-290 Sensor or MPS Evaluation Kit.



MPS MINI FORM FACTOR	
SKU	Description
MPS310-MN2505-00	MPS A3 Refrigerant Gas Sensor (R-290), Mini, V2, UART + Analog Out
MPS310-MN2509-00	MPS A3 Refrigerant Gas Sensor (R-290), Mini, V2, UART + Analog Out + Auto Start



MPS S4 (INTRINSICALLY SAFE) FORM FACTOR	
SKU	Description
MPS310-S42505-E0	MPS A3 Refrigerant Gas Sensor (R-290), S4, V2, 5-Pin, UART + Analog Out
MPS310-S42509-E0	MPS A3 Refrigerant Gas Sensor (R-290), S4, V2, 5-Pin, UART + Analog Out + Auto Start
MPS310-S42309-E0	MPS A3 Refrigerant Gas Sensor (R-290), S4, V2, 3-Pin, Analog Out + Auto Start



SKU	Description
MPS999-S40000-99	MPS S4 Evaluation Kit (not pictured; S4 sensor not included)
MPS999-MN0000-99	MPS Mini Evaluation Kit (Mini sensor not included)



Nevada Nanotech Systems Inc.
 1395 Greg Street, Suite 102
 Sparks, Nevada 89431
 United States
 Tel: +1 775 972 8943
 Fax: +1 775 972 8078
info@nevedanano.com
www.nevedanano.com

Specifications are subject to change without notice.

SM-DS-0015-06